

IT EXPIRES ON JULY 31st 2024



www.gerardi.it

From 6th to 8th
MARCH 2024



ENGLISH

SPECIAL OFFER

**QUICK
CHANGE TABLES**
Reduce downtime
and accelerate
your production

NEW 2024! REQUEST MORE INFORMATION

MODULAR BROACHING DRIVEN TOOLS

Upgrade your CNC Lathe

It creates grooves and internal
cavities directly on the lathe



Go to the Brochure

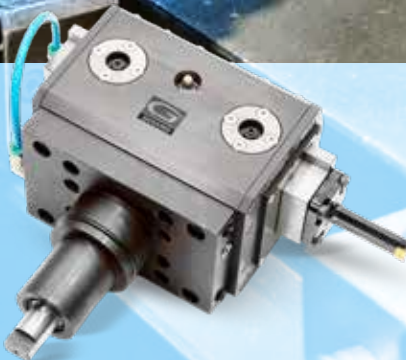

COMPACT GRIP Vises

Self centering vises with reversible jaws - Ideal for 5 axis machining centres

Art.650

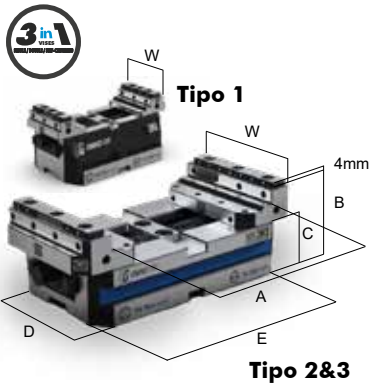

Standard equipment: 1 Box wrench, 1 Calibrated centering, 2 positioning key-nuts and 2 self-centering key-nuts, 2 top jaw inserts Art. 650T G11 pitch 11 mm

+ Magnetic Workstop Art. 370EM

Type	Jaw width W	Max opening A	Vise height B	Base height C	Base width D	Base width E	Kg	Code	LIST PRICE €	SPECIAL PRICE €
1 12kN	50	54	65	45	79,9	80	1,9	7.65.01080	777	649
		94				120	2,7	7.65.01120	897	749
		134				160	3,4	7.65.01160	1.015	849
2 22kN	88	96	65	38	89,9	120	3,6	7.65.02120	955	749
		136				160	4,4	7.65.02160	1.075	849
		176				200	5,2	7.65.02200	1.194	949
		216				240	5,8	7.65.02240	1.314	1.049
3 32kN	123	133	89	57	124,9	160	9,1	7.65.03160	1.552	1.249
		183				210	10,9	7.65.03210	1.790	1.349
		233				260	12,8	7.65.03260	2.029	1.449
		283				310	14,8	7.65.03310	2.387	1.749
		333				360	17	7.65.03360	2.625	1.949

MAXIGRIP

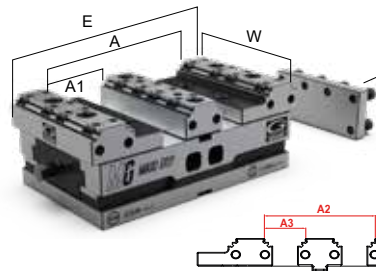

Art.685

MaxiGrip vise - 3 clamping in 1 - Self-Centering, Double and Single

Type	kN	A	A1	A2	A3	W	E	Kg	Code	LIST PRICE €	SPECIAL PRICE €
4x270	41	200	83	104	35	158	270	28,5	76854270	2.920	2.299
4x420		344	155	248	107	420	40	76854420	3.870	3.099	

Art.684

MaxiGrip vise - Only Self-centering

Type	kN	A	A1	A2	A3	W	E	Kg	Code	LIST PRICE €	SPECIAL PRICE €
4x270	41	200	-	104	-	158	270	25	76844270	2.500	1.999
4x420		344	-	248	-	420	36	76844420	3.450	2.799	

RISERS FOR COMPACT GRIP VISES

Art.651H

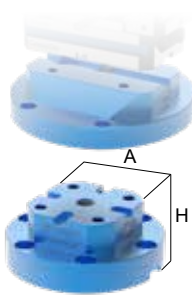

Type	Min A	H=50			H=75			H=100		
		Code	LIST PRICE €	SPECIAL PRICE €	Code	LIST PRICE €	SPECIAL PRICE €	Code	LIST PRICE €	SPECIAL PRICE €
1	80	7.65.1H1080/050	414	350	7.65.1H1080/075	425	350	7.65.1H1080/100	437	350
	120	7.65.1H1120/050	492	400	7.65.1H1120/075	517	400	7.65.1H1120/100	539	400
	160	7.65.1H1160/050	588	450	7.65.1H1160/075	620	500	7.65.1H1160/100	654	500
2	120	7.65.1H2120/050	588	450	7.65.1H2120/075	620	500	7.65.1H2120/100	654	500
	160	7.65.1H2160/050	588	500	7.65.1H2160/075	620	550	7.65.1H2160/100	654	550
	200	7.65.1H2200/050	588	550	7.65.1H2200/075	620	600	7.65.1H2200/100	654	600
	240	7.65.1H2240/050	727	600	7.65.1H2240/075	773	600	7.65.1H2240/100	820	650
3	160	7.65.1H3160/050	680	650	7.65.1H3160/075	726	650	7.65.1H3160/100	769	650
	210	7.65.1H3210/050	680	650	7.65.1H3210/075	726	700	7.65.1H3210/100	769	700
	260	7.65.1H3260/050	1.047	950	7.65.1H3260/075	1.106	950	7.65.1H3260/100	1.167	950
	310	7.65.1H3310/050	1.085	1.000	7.65.1H3310/075	1.146	1.000	7.65.1H3310/100	1.207	1.000
	360	7.65.1H3360/050	1.255	1.100	7.65.1H3360/075	1.326	1.100	7.65.1H3360/100	1.398	1.100

PYRAMIDAL SUPPORT FOR 5TH AXIS CENTRES - INCLUDED MOUNTED & ALIGNED VISES

Art.643H



Standard equipment: 12 Vise holding clamps Art.298 CGR, 1 Eyebolt, 1 Centering pin, Pair of keynuts Art.297

+ MOUNTING & ALIGNEMENT INCLUDED

Aluminum pyramidal support, it permits the simultaneous mounting of 3 CompactGrip vises (with or without quick change tables) tilted at 45° or 60° thus increasing the working space and allowing the contemporary machining of multiple workpieces even in hardly reachable points.

Type	Height	Code	LIST PRICE €
1 (Ø200)	170	7.64.3H100	1.763
2 (Ø308)	136	7.64.3H200	2.157
3 (Ø360)	190	7.64.3H300	2.314

KIT 1

Art. 643H + N°3 Art.650 T.1x120



60°

Code	LIST PRICE €	SPECIAL PRICE €
7.65.01120	4.373	3.400

KIT 2

Art. 643H + N°3 Art.650 T.2x200



* Check the machine spindle turning

30°

45°

Code	LIST PRICE €	SPECIAL PRICE €
7.65.02200	5.571	4.200

KIT 3

Art. 643H + N°3 Art.650 T.3x210



* Check the machine spindle turning

45°

Code	LIST PRICE €	SPECIAL PRICE €
7.65.03210	7.525	5.300

STANDARD FLEX Vises

Innovative comb system for quick pull-down jaw plates change - Ideal for vertical machining centres

Art.1A

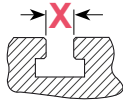

Std Equipment: 1 workstop, 2 positioning key-nuts for 16 mm slot, 2 inserts Art. 291, 1 box wrench, 1 "T" wrench

+ 4 Holding Clamps Art.298

StandardFLEX series precision modular vise

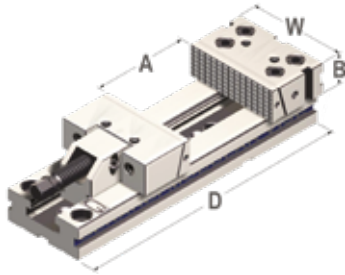

Type	Max opening A	Jaw width W	Jaw Height B	Base Length D	Code	LIST PRICE €	SPECIAL PRICE €
2 25kN	150	121 mm	38	345	1.1A.20000	925	789
	200	146 mm	48	420	1.1A.32000	1.112	839
3 30kN	300			520	1.1A.33000	1.283	949
	200			455	1.1A.42000	1.414	1.189
	300	171 mm	58	555	1.1A.43000	1.555	1.239
4 30kN	400			655	1.1A.44000	1.696	1.339
	200			495	1.1A.52000	1.846	1.489
5 40kN	300	196 mm	63	595	1.1A.53000	2.210	1.789
	400			695	1.1A.54000	2.582	2.039

REDUCTION UP TO 20%

* When bought with a complete vise

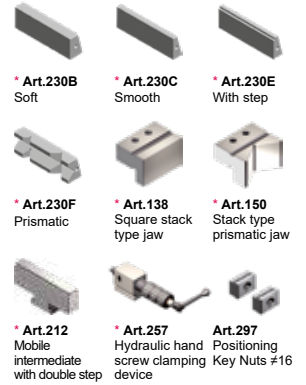

EXTRA LONG Vises

Vises with the extra large base dimension, much longer than std vises - Ideal for vertical machining centres

Art.21

(Single Clamping)

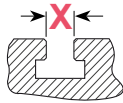

Std Equipment: 1 workstop, 2 positioning key-nuts for 16 mm slot, 2 inserts Art. 291, 1 box wrench, 1 "T" wrench

+ 6 Holding clamps Art. 298

XL modular vise with standard dotation

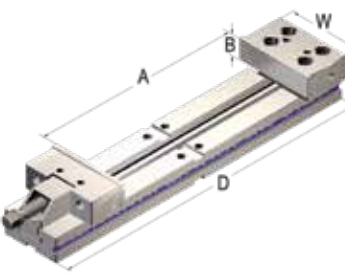

Type	Max opening A	Jaw width W	Jaw Height B	Base Length D	Kg	Code	LIST PRICE €	SPECIAL PRICE €
2 25kN	320	125 mm	40	520	17	2.21.23200	1.147	800
	360			580	32	2.21.33600	1.425	1.000
3 30kN	460	150 mm	50	680	35	2.21.34600	1.578	1.150
	500			766	52	2.21.45000	1.828	1.350
	600	175 mm	60	866	56	2.21.46000	1.990	1.450
4 30kN	700			966	61	2.21.47000	2.159	1.550

REDUCTION UP TO 20%

* When bought with a complete vise

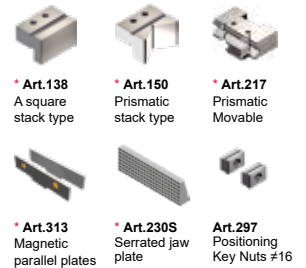

Parallel MAGNETIC PLATES

Wide range of heights available on page 4.27 - General price list w17

REDUCTION UP TO 40%

FOR VISES STANDARD & STANDARDFLEX ART.1 e ART.1A

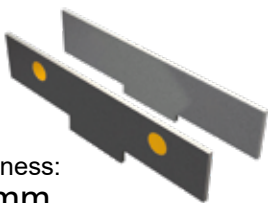

Thickness:
2,8mm

Art.414

Also Available Universal Parallel magnetic plates



Type	Pair of guided parallels magnetic plates	LIST PRICE EACH €	Art.310		Art.311	
			PRICE EACH €	KIT PRICE €	PRICE EACH €	KIT PRICE €
1	73	50	300	-	-	
2	93	65	390	-	-	
3	116	75	450	70	700	
4	136	90	540	80	800	
5	155	100	600	90	900	
6	176	120	720	100	1.000	



AUTOMATION Kits

Unit with pneumatic control and single effect cylinder - Ideal for vertical machining centres

FOR VISES STANDARD & STANDARDFLEX ART.1 e ART.1A

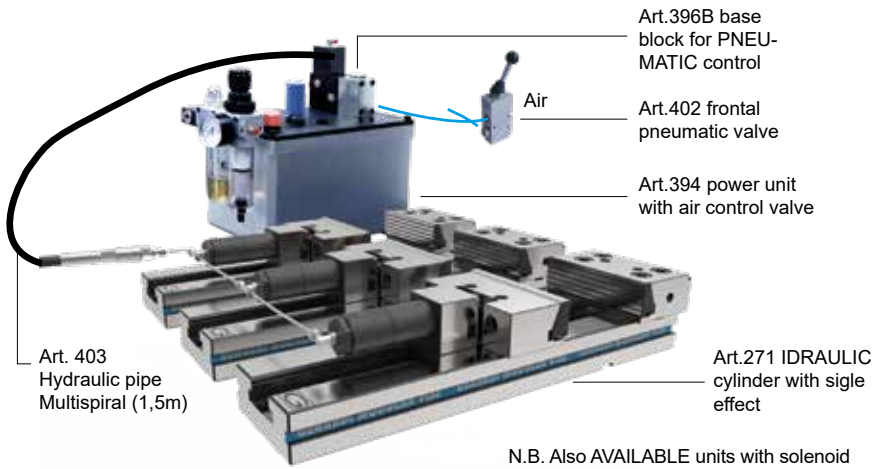

N.B. Also AVAILABLE units with solenoid valves electromagnetics FOR CNC

WISE NOT INCLUDED

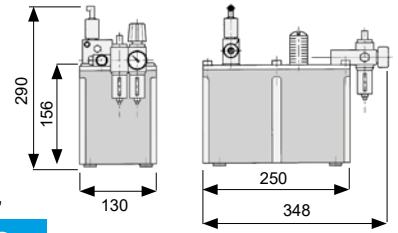

N°1 CLAMPING

Art.392

Type	Stroke Art.271	Code	LIST PRICE €	SPECIAL PRICE €
2	26	4.39.22000	1.872	1.499
3		4.39.23000	1.884	1.499
4		4.39.24000	1.917	1.499
5	40	4.39.25000	2.109	1.599

*Art.405H Suitable galvanized steel pipe Ø6 (m1,0)
(Not included) Codice: 4.40.5H000

SIMULTANEOUS VISES CLAMPING KIT

Art.392/2

(Art.271- 394 - 402 - 403)
N°2 SYMULTANEOUSLY CLAMPING
Art.392 + N°1 Art.271

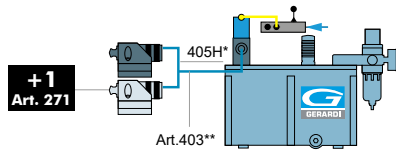

Type	Code	LIST PRICE €	SPECIAL PRICE €
2	4.39.22002	2.255	1.799
3	4.39.23002	2.277	1.799
4	4.39.24002	2.345	1.799
5	4.39.25002	2.725	2.099

Art.392/3

N°3 SYMULTANEOUSLY CLAMPING
Art.392 + N°2 Art.271

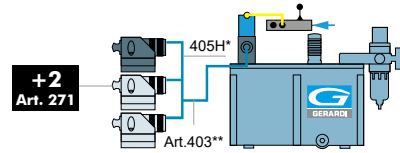

Type	Code	LIST PRICE €	SPECIAL PRICE €
2	4.39.22003	2.634	2.099
3	4.39.23003	2.667	2.099
4	4.39.24003	2.767	2.099
5	4.39.25003	3.341	2.499

Art.392/4

N°4 SYMULTANEOUSLY CLAMPING
Art.392 + N°3 Art.271

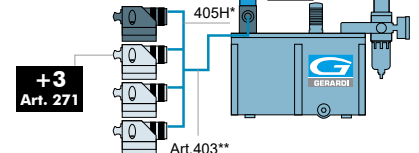

Type	Code	LIST PRICE €	SPECIAL PRICE €
2	4.39.22004	3.017	2.399
3	4.39.23004	3.059	2.399
4	4.39.24004	3.196	2.399
5	4.39.25004	3.958	2.999

INDEPENDENT CLAMPING GROUP KIT

*Art.403 (Included) Hydraulic pipe Multispiral 760bar complete with rapid connection Art. 270A (m 1,5) Codice: 4.40.30000

Art.392A/2

(Art.271- 394 - 402 - 403)
N°2 SYMULTANEOUSLY CLAMPING
Art.392 + N°1 Art.407B

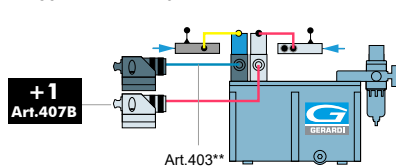

Type	Code	LIST PRICE €	SPECIAL PRICE €
2	4.39.2A202	3.063	2.399
3	4.39.2A302	3.083	2.399
4	4.39.2A402	3.161	2.399
5	4.39.2A502	3.639	2.799

Art.392A/3

N°3 SYMULTANEOUSLY CLAMPING
Art.392 + N°2 Art.407B

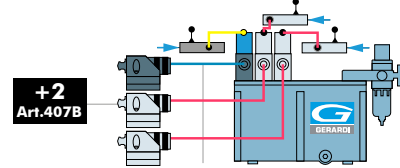

Type	Code	LIST PRICE €	SPECIAL PRICE €
2	4.39.2A203	3.564	2.799
3	4.39.2A303	3.596	2.799
4	4.39.2A403	3.695	2.799
5	4.39.2A503	4.247	3.299

Art.392A/4

N°4 SYMULTANEOUSLY CLAMPING
Art.392 + N°3 Art.407B

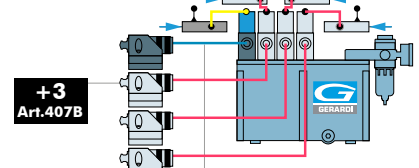

Type	Code	LIST PRICE €	SPECIAL PRICE €
2	4.39.2A204	4.413	3.599
3	4.39.2A304	4.455	3.599
4	4.39.2A404	4.584	3.599
5	4.39.2A504	5.319	4.199

FMS Vises

For single, double and self-centering clamping - Ideal for vertical & horizontal machines

Art.855

Base Body 3 in 1

Art.855A

Base Body
Self-Centering Only

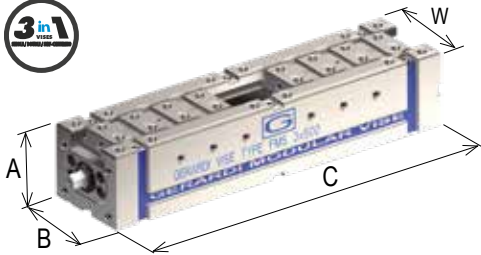

Type	Base eight A	Base width B	Base length C	Code	LIST PRICE €	Code	LIST PRICE €
2 (94mm) 25kN	90	95	400	5.85.52400	1.365	5.85.52400A	1.447
			500	5.85.52500	1.848	5.85.52500A	1.947
			600	5.85.52600	2.041	5.85.52600A	2.114
3 (124mm) 30kN	100	125	500	5.85.53500	1.773	5.85.53500A	1.864
			600	5.85.53600	2.452	5.85.53600A	2.559
4 (144mm) 30kN	120	145	600	5.85.54600	2.258	5.85.54600A	2.337

COMPOSE YOUR VISE WITH THE HUNDREDS OF JAWS AVAILABLE

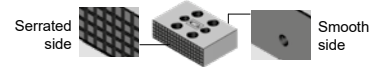

DOUBLE CLAMPING CONFIGURATION

Art.860

Double vises with serrated jaws

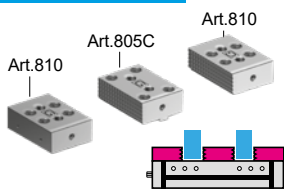

Type	Code	LIST PRICE €	SPECIAL PRICE €
2	5.86.02400	1.794	1.400
	5.86.02500	2.281	1.800
	5.86.02600	2.471	1.950
3	5.86.03500	2.264	1.800
	5.86.03600	2.941	2.300
4	5.86.04600	2.908	2.300

Art.863

Double vise with step jaws

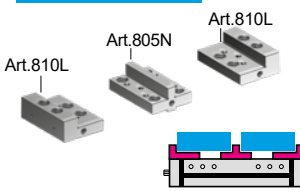

Type	Code	LIST PRICE €	SPECIAL PRICE €
2	5.86.32400	1.952	1.550
	5.86.32500	2.436	1.900
	5.86.32600	2.628	2.100
3	5.86.33500	2.420	1.900
	5.86.33600	3.098	2.450
4	5.86.34600	3.104	2.450

Art.865

Double vise with quick change pull down jaws (comb system)

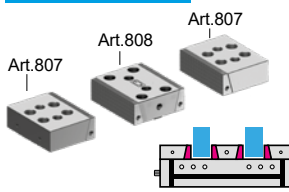

Type	Code	LIST PRICE €	SPECIAL PRICE €
2	5.86.52400	2.120	1.700
	5.86.52500	2.604	2.100
	5.86.52600	2.798	2.200
3	5.86.53500	2.735	2.200
	5.86.53600	3.418	2.700
4	5.86.54600	3.540	2.800

Art.866

Double vise with floating step jaws (3x5)

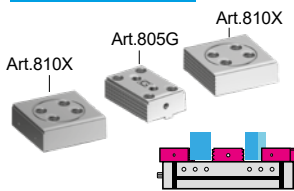

Type	Code	LIST PRICE €	SPECIAL PRICE €
2	5.86.02400	2.242	1.800
	5.86.02500	2.728	2.200
	5.86.02600	2.918	2.300
3	5.86.03500	2.761	2.200
	5.86.03600	3.439	2.700
4	5.86.04600	3.391	2.700

Art.867

Double vise with floating step jaws with adjustable inserts

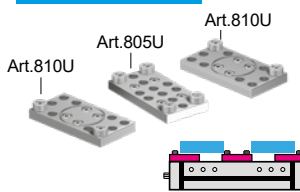

Type	Code	LIST PRICE €	SPECIAL PRICE €
2	5.86.72400	2.618	1.999
	5.86.72500	3.048	2.328
	5.86.72600	3.293	2.516
3	5.86.73500	3.171	2.423
	5.86.73600	3.850	2.941
4	5.86.74600	3.874	2.960

* SELF-CENTERING CONFIGURATION ONLY

* For self-centering configuration ONLY, spacer Art.850T included in the price

Art.855A

Base Body -
Self-Centering Only

Art.810

2 Serrated jaws

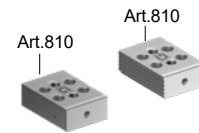
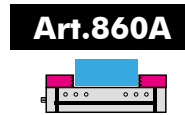

Type	* LIST PRICE €
2	1.647
	2.135
	2.325
	2.100
3	2.776
	2.682

Art.855A

Base Body -
Self-Centering Only

Art.810L

2 Step jaws

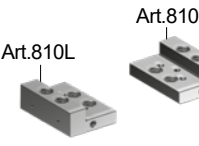
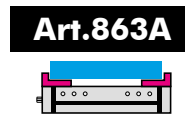

Type	* LIST PRICE €
2	1.722
	2.206
	2.398
	2.172
3	2.848
	2.775

Art.855A

Base Body -
Self-Centering Only

Art.807

2 Quick change
pull down jaws

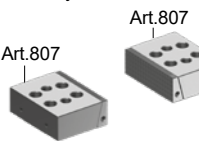
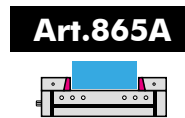

Type	* LIST PRICE €
2	1.846
	2.330
	2.524
	2.332
3	3.015
	3.008

Art.855A

Base Body -
Self-Centering Only

Art.814 (n°2)

Art.805V (n°2)

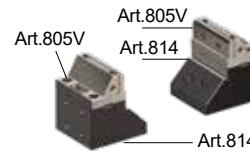
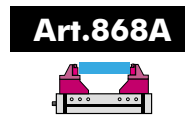

Type	* LIST PRICE €
2	2.113
	2.578
	2.757
	2.590
3	3.246
	3.328

Art.855A

Base Body -
Self-Centering Only

Art.810J

2 Prismatic jaws

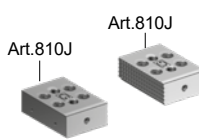
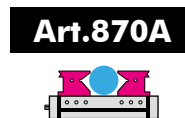

Type	* LIST PRICE €
2	1.882
	2.367
	2.558
	2.377
3	3.054
	3.108

IDEAL FOR 5 AXIS MACHINING CENTRES

MULTIFLEX Vises

For multiple clamping from 1 to 19 workpieces of various sizes - Ideal for vertical & horizontal machines



Std Equipment : 1 "T" wrench, 2 positioning keynuts and 4 workstops. Each vise is supplied for 4 workpieces clamping.

+ 6 holding clamps Art.298

(* Types supplied for 3 workpieces clamping)

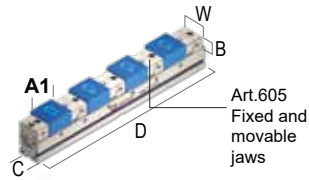

Art.605 Fixed and movable jaws

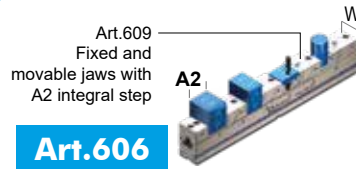

Art.609 Fixed and movable jaws with A2 integral step

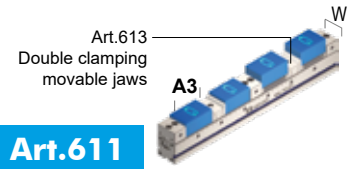

Art.613 Double clamping movable jaws

Art.600

Art.600W

Art.606

Art.611

Type	B	C ^{+0/-0.02}	D	W	A1 mm	Code	LIST PRICE €	SPECIAL PRICE €	A2 mm	Code	LIST PRICE €	SPECIAL PRICE €	A3 mm	Code	LIST PRICE €	SPECIAL PRICE €
1 20kN	32/25	50	49	300	4x8	6.60.01300	1.204	749	* 3x19	6.60.61300	1.822	1.200	* 3x21	6.61.11300	1.822	1.200
				400	4x33	6.60.01400	1.308	849	4x23	6.60.61400	1.898	1.300	4x46	6.61.11400	1.898	1.300
				500	4x58	6.60.01500	1.425	949	4x48	6.60.61500	2.013	1.400	4x71	6.61.11500	2.013	1.400
				600	4x83	6.60.01600	1.553	1.049	4x73	6.60.61600	2.141	1.500	4x96	6.61.11600	2.130	1.500
				700	4x108	6.60.01700	1.736	1.149	4x97	6.60.61700	2.327	1.600	4x121	6.61.11700	2.327	1.600
2 30kN	40	75	74	400	4x12	6.60.02400	1.566	1.099	* 3x28	6.60.62400	2.266	1.550	4x34	6.61.12400	2.266	1.550
				500	4x37	6.60.02500	1.681	1.249	4x24	6.60.62500	2.386	1.650	4x59	6.61.12500	2.386	1.650
				600	4x62	6.60.02600	1.811	1.349	4x49	6.60.62600	2.517	1.750	4x84	6.61.12600	2.517	1.750
				700	4x87	6.60.02700	1.940	1.449	4x74	6.60.62700	2.647	1.850	4x109	6.61.12700	2.647	1.850
				800	4x112	6.60.02800	2.114	1.549	4x99	6.60.62800	2.832	1.950	4x134	6.61.12800	2.832	1.950
3 40kN	60	100	99	900	4x137	6.60.02900	2.302	1.749	4x124	6.60.62900	3.021	2.050	4x158,5	6.61.12900	3.021	2.050
				700	4x59	6.60.03700	2.244	1.649	4x44	6.60.63700	3.057	2.150	4x77	6.61.13700	3.057	2.150
				800	4x84	6.60.03800	2.428	1.749	4x69	6.60.63800	3.245	2.250	4x102	6.61.13800	3.245	2.250
				900	4x109	6.60.03900	2.619	1.949	4x94	6.60.63900	3.431	2.450	4x127	6.61.13900	3.431	2.450
				1000	4x134	6.60.03100	2.869	2.149	4x119	6.60.63100	3.682	2.650	4x152	6.61.13100	3.682	2.650

FOR MAGNETIC PARALLEL PLATES AND PARALLEL JAW PLATES

Art.616
Pair of magnetic parallel plates for Art. 600



REDUCTION UP TO
20%

When bought with a complete vise



Art.610E
Parallel jaw plate for Art.606

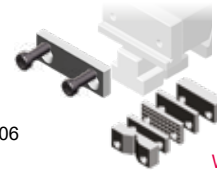

REDUCTION UP TO
20%

When bought with a complete vise

MULTITASKING Vises

Self-centering and eccentric vises - Ideal for 5 axis machining centres

Art.640

! Possible request of 2 Art.645T jaws instead Art.645E

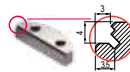

Standard equipment : 1 workstop, 1 exagonal wrench, pair of positioning key-nuts Art.297, 1 straight pin Art.640P

Type	1	2	3x166	3x266
Code	6.64.01000	6.64.02000	7.64.03166	7.64.03266
LIST PRICE €	1.858	2.285	2.658	2.785
SPECIAL PRICE €	1.049	1.249	2.039	2.124



Simple riser for Art.640 vise
MOUNTING INCLUDED



Steel risers with zero point for Art.640 for quick change. Standard equipment : 1 pull-stud Art.10S / 11S 1 teflon cap with O-ring Art.9, 1 positioning pin Art.640P, 1 shoulder calibrated screw Art.79



Art.641H

Compatible

Type	1	2	3x166	3x266
Code	7.64.1H100AL /100	7.64.1H200AL /100	7.64.1H3166AL /100	7.64.1H3266AL /100
LIST PRICE €	640	753	769	1.167
SPECIAL PRICE €	400	450	600	900

Art.63

Compatible

Type	1	2	2
Height H	100	125	163
Code	9.63.10000	9.63.20000	9.64.20000
LIST PRICE €	1.222	2.066	3.448
SPECIAL PRICE €	949	1.449	-

Art.64

Art.645B
Soft Jaw



Art.645C
Smooth Jaw



Art.645D
Serrated Jaw



Art.645E
Step Jaw



Art.645F
Prismatic Jaw



Art.645T
Grip Jaw



Type	Code	LIST PRICE €	SPECIAL PRICE €
1	6.64.5B100	102	77
2	6.64.5B200	122	93
3	6.64.5B300	159	121

Type	Code	LIST PRICE €	SPECIAL PRICE €
1	6.64.5C100	102	77
2	6.64.5C200	122	93
3	6.64.5C300	159	121

Type	Code	LIST PRICE €	SPECIAL PRICE €
1	6.64.5D100	102	77
2	6.64.5D200	122	93
3	6.64.5D300	159	121

Type	Code	LIST PRICE €	SPECIAL PRICE €
1	6.64.5E100	115	87
2	6.64.5E200	134	102
3	6.64.5E300	171	130

Type	Code	LIST PRICE €	SPECIAL PRICE €
1	6.64.5F100	129	98
2	6.64.5F200	146	111
3	6.64.5F300	185	141

Type	Code	LIST PRICE €	SPECIAL PRICE €
1	6.64.5T100	129	98
2	6.64.5T200	146	111
3	6.64.5T300	185	141

GRIP MATIC Vises

Hydraulic or pneumatic vise double effect - Ideal for 5 axis machining centres

Art.670

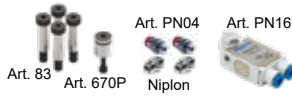

Standard equipment: - 4x Calibrated screws (Art.83) - Centering pin (Art.670P)
- 2 Niplon o 2 Art.PN04 - No return valve (Art.PN16)



Vise base pneumatic or Hydraulic, ideal for 5 axis machining centres.

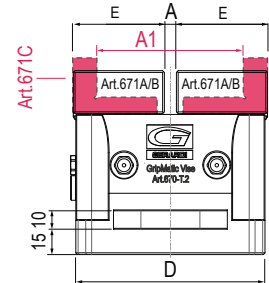
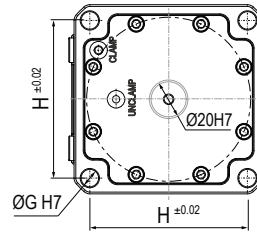
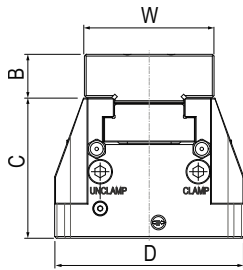

Type	Jaw width W	Min opening A	Max opening A1	Vise height C+B	Base height C	Base length D	Jaw length E	Pitch centering and fixing holes H	Pneumatic		Hydraulic		LIST PRICE €	SPECIAL PRICE €	
									Air pressure	Clamping force	Pressure	Clamping force			
2	74	6,4	88,9	105	80	106	52	90	7 kN	7.67.0PN20	30BAR	19 kN	7.67.0ID20	1.790	1.400
3	99	8,5	130,2	135	105	166	78	140	14,4 kN	7.67.0PN30	30BAR	37,5 kN	7.67.0ID30	2.387	1.850
4	124	12	162	165	130	206	96	170	16,9 kN	7.67.0PN40	25 BAR	47 kN	7.67.0ID40	3.162	2.400



Art.671A
Soft Jaw



Art.671B
Soft narrow jaw

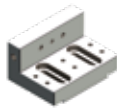

Art.671C
Jaw for narrow width standard jaw plates



Art.243
Hardened grooved straight jaw plate



Art.245
Hardened smooth straight jaw plate



Art.247G
Straight plate with GRIP inserts

INTERFACED PLATE FOR GRIP MATIC VISES - IDEAL FOR 5 AXIS MACHINING CENTRES

Art.670CP SEMI-AUTOMATIC

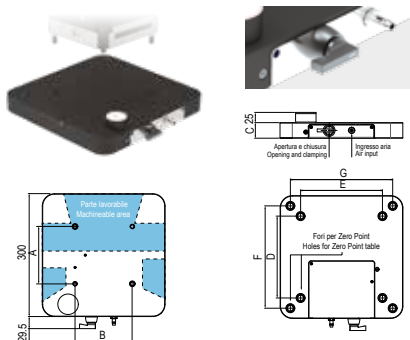

Interface plate for GripMatic vise Art.670PN semi-automatic quick coupling air input and manual system control through a selector.

Type	Holes pitch A	Holes pitch B	Plate height C	Pitch holes (Zero Point) D	Pitch holes (Zero Point) E	Pitch holes (Zero Point) F	Pitch holes (Zero Point) G	Air pressure	Clamping force	Code	LIST PRICE €
2	90	90	38	200	200	250	250	Max 10BAR	7 kN	7.67.0CP20	2.271
3	140	140	38	200	200	250	250		14,4 kN	7.67.0CP30	2.271
4	170	170	38	200	200	250	250		16,9 kN	7.67.0CP40	2.271

Art.670AP AUTOMATIC



Interface plate for GripMatic vise Art.670PN automatic with air input through the machine table and possible to be controlled directly by the CNC. This plate can be fully tailored according the characteristics of the machine (workpiece positioning check and cleanliness).

* Minimum price, PERSONALIZATION INCLUDED

100% CUSTOMIZABLE PLATE

Type	Air pressure	Clamping force	ART.670 Pneumatic Code	LIST PRICE €*
2	Max 10BAR	7 kN	7.67.0AP20	2.497
3		14,4 kN	7.67.0AP30	2.497
4		16,9 kN	7.67.0AP40	2.497

